



LX3V-2PT-BD

User manual



Website: <http://www.we-con.com.cn/en>

Technical Support: support@we-con.com.cn

Skype: fcwkkj

Phone: 86-591-87868869

QQ: 1043098682

Technical forum: <http://wecon.freeforums.net/>



1. Mounting instruction

Before the installation must be ensure that the PLC host and BD associated equipment power off. Please install the BD module in the corresponding position of the PLC, and lock the four standard screws. If environmental dust is bigger, please cover BD right part by PLC's cover. Please do not power operation.

Caution

1) This BD module only support the following firmware versions or later. Users can check the PLC firmware version in D8001.

- LX3VP:25103;
- LX3VE: 25201;
- LX3V-A2:25014;
- LX3V-A1: 22006;

When mounting module to PLC, all the lights are blinking after power ON PLC please purchase new PLC.

- 2) Please fixed BD module on the PLC, poor contact may lead to failure.
 3) BD module and top cover of PLC's tightening torque is 0.3 ~ 0.6 N.m.

Warning

Make sure to power off the PLC before mounting or removing the BD module and put the cover in right place.

2. Special feature

- 1) It adds two analog inputs (if access two BD modules can be increased 4 analog inputs). The module is mounted on top of PLC, so there is no need to change the PLC installation area.
 2) Digital to analog conversion is performed by PT100 in LX3V-2PT-BD, and the converted digital value is stored in a special registers. However, the characteristics of the analog to digital converter cannot be adjusted. The soft elements corresponding to the different expansion ports are also different. Address assignment in the following table.

Table 2-1

Extension port 1 (far away from PLC LED)	Extension port 2 (near PLC LED)
--	---------------------------------

Address	Description	Address	Description
M8112	The flag of RTD type in CH1 OFF: RTD Type is PT100 ON: turn off	M8116	The flag of RTD type in CH1 OFF: RTD Type is PT100 ON: turn off
M8113	The flag of RTD type in CH2 OFF: RTD Type is PT100 ON: turn off	M8117	The flag of RTD type in CH2 OFF: RTD Type is PT100 ON: turn off
D8112	CH1's temperature at 0.1 °C units	D8116	CH1's temperature at 0.1 °C units
D8113	CH2's temperature at 0.1 °C units	D8117	CH2's temperature at 0.1 °C units

3.Dimension

Table 3-1

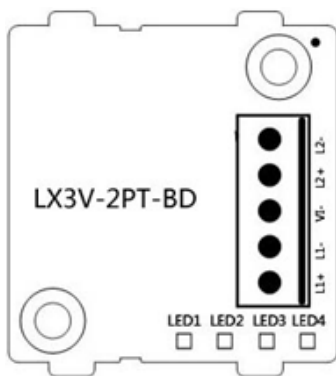

Sensor type: 2 or 3 wires PT100	
L1+	First channel PT100 signal input (+)
L1-	First channel PT100 signal input (-)
L2+	Second channel PT100 signal input (+)
L2-	Second channel PT100 signal input (-)
VI-	Common

LED lights indicating

- 1) LED1: ON when power ON.
- 2) LED2: flashes when communications.
- 3) LED3 (PT 1): On indicates enable, OFF indicates disable, flicker indicates exceeding the measurement range.
- 4) LED4 (PT 2): On indicates enable, OFF indicates disable, flicker indicates exceeding the measurement range.

If the BD module is plugged into the old firmware version when on the host, all LEDs will be flashing.

4.Specifications

- 1) Please refer to the LX3V user manual for the general specification of LX3V-2PT-BD.
- 2) LX3V-2PT-BD is powered supply by LX3V main unit.

Table 4-1

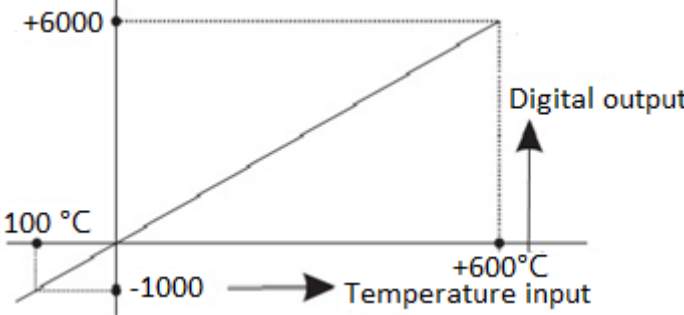
Item	Explanation
Analog circuitry	DC 24V \pm 10%, 50mA
Digital circuitry	DC 5V, 90mA (From the PLC internal power supply)
Celsius	Read data by buffers
Analog input signal	PT100 sensor, 3 wires, 4 channels (CH1, CH2, CH3, CH4), 3850PPM/ $^{\circ}$ C
Sensor current	1mA
Compensation range	-100 $^{\circ}$ C - 600 $^{\circ}$ C
Digital output	-1000 - 6000
	12 bits total, 11 bits for data and 1 bit for sign
Accuracy	0.2 $^{\circ}$ C - 0.3 $^{\circ}$ C
Overall accuracy	\pm 1%
Conversion rate	700ms
Conversion characteristics	

5. Wiring

Explanation:

- 1) 2-wire PT100: when using channel 1, short-circuit L1+ and VI-, connect PT100's 2 wires to L1+ and L1- respectively. The same setting in channel 2.
- 2) 3-wire PT100: when using channel 1, two same color wires, connected to the L1- and VI-, the third one connect to L1+.

Warning:

Make sure cut off the electricity before installation/disassembly, to prevent electric shock or product damages.

Caution:

- 1) Stay away from high-voltage cables to avoid interference or surge;
- 2) Grounding is required, but please do not share the ground site with high-voltage cable;
- 3) Do not weld any cable ends, and make ensure that the number of connecting cables, no more than a predetermined number;

5.1 Suitable cable

Use AWG25-16 to connect the output equipment

The maximal screwing torque is from 0.5 to 0.6N.m

Table 5-1

Line type	Cross sectional area(mm ²)	End-of-pipe treatment	
AWG26	0.1288	Stranded cable: stripped jacket, rub Conductor, then connect the cable.	
.....	Single-core cable: stripped jacket, Then connect the cable.	

5.2 Input mode

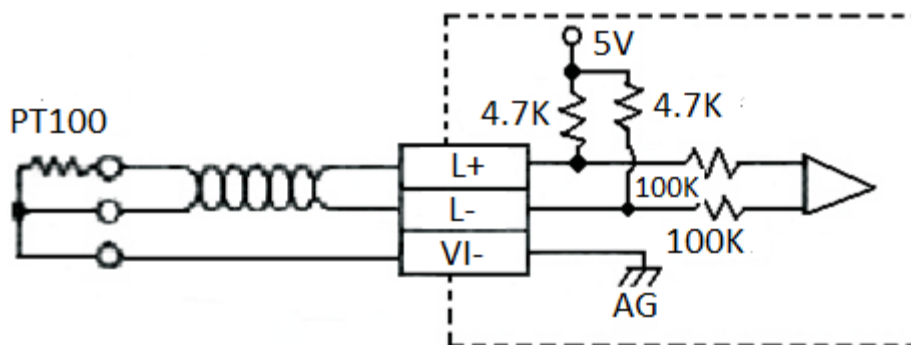

Figure 5-1

6.Examples

The value of each channel's PT100 is storage in the registers (D8112, D8113) in the form of digital.

For output, in each "END" instruction, M8114 and M8115 convert the digital value into an analog output.

6.1 Basic Program Examples

Caution

- 1) M8112 and M8113 are used to analog to digital conversion for CH1 and CH2;
- 2) LX3V-2PT-BD only supports PT100;
- 3) When M8112-M8115 is ON, the channels will not work, all show "0";
- 4) Don't try to change the value in D8112 or D8113, when finished the A/D conversion;

The following project sets CH1 and CH2 as PT100 input, and the value is storage in D0 and D2.

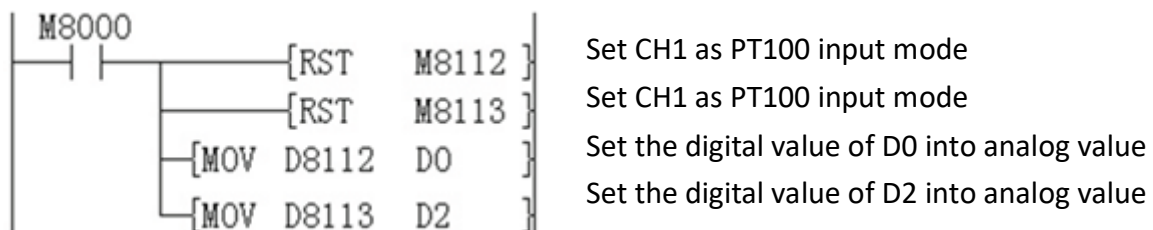

6.2. Examples of Applications

Since the LX3V-2PT-BD does not have offset and gain functions, if it needs for the values out of the standard specifications, Additional programming orders will be needed to multiply or divide the converted value.

Caution

Since the use of additional programming orders, the converted precision and resolution of the analog value are different with the specifications.

The original range of the analog output does not change.

Thermocouple input mode

In RTD input mode, 2PT converts analog value to digital value in degrees Celsius. If in the program was a degree Fahrenheit as a unit it needs to be converted to Celsius value.

Fahrenheit and Celsius conversion formula, Fahrenheit = Celsius * 9/5 + 32, the unit is 0.1 °C

$$D10 = D8112 * 9$$

$$D12 = D10 / 5$$

$$D0 = D12 + 320$$

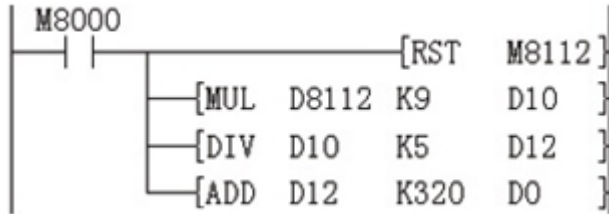
$$D0 = D8112 * 9 / 5 + 320$$

Version: V1.0.1

Date: Feb 2018